

A Series Mini Walkie Pallet Truck

Distinguishing Marks	1.1	Manufacturer	HANGCHA GROUP CO.,LTD.
		HCFA Model	WP15
	1.2	Manufacturer's Type Designation	CBD15-A2MC1
	1.4	Operator Type: hand, pedestrian, standing, seated, order-picker	Walkie
	1.5	Rated Capacity/Rated Load	Q (lb/kg) 3000/1500
Weight	1.6	Load Centre Distance	c (in/mm) 24/600
	1.8	Load Distance, centre of drive axle to fork	x (in/mm) 37.8/960
Tires & Chassis	1.9	Wheelbase	y (in/mm) 50.6/1285
	2.1	Service Weight(Including battery)	lb/kg 485/220
		Battery Weight	lb/kg 110/50
	3.1	Tires: solid rubber, superelastic, pneumatic, polyurethane	PU
	3.2	Tire Size, front	in/mm φ8.3x2.8 / φ210x70
	3.3	Tire Size, rear	in/mm 2×φ3.1x2.5 / 2×φ80x64
	3.4	Additional Wheel (dimensions)	in/mm φ2.8x1.6 / φ70x40
	3.5	Wheels, number front / rear (x = driven wheels)	1x+2/4
	3.6	Tread, front	b ₁₀ (in/mm) 15.9/404
	3.7	Tread, rear	b ₁₁ (in/mm) 15.7/400
Dimensions	4.4	Lift	h ₃ (in/mm) 4.7/120
	4.15	Fork Height, lowered	h ₁₃ (in/mm) 3.1/80
	4.19	Overall Length	l ₁ (in/mm) 65.7/1669
	4.21	Overall Width	b ₁ in (mm) 22.4/27.1 (568/688)
	4.22	Fork Dimensions	s/e/l in (mm) 2.0/6.3/45.3 (50/160/1150)
	4.25	Distance between Fork-Arms	bs in (mm) 22.0/26.8 (560/680)
	4.32	Ground Clearance, centre of wheelbase	m ₂ (in/mm) 1.2/30
	4.34.1	Aisle Width for pallets 39" x 47" Crossways	Ast (in/mm) 72.8/1850 ¹⁾
	4.34.2	Aisle Width for pallets 31.5" x 47" Lengthways	Ast (in/mm) 74.8/1900 ²⁾
	4.35	Turning Radius	Wa (in/mm) 55.1/1400 ³⁾
	Performance Data	5.1	Travel Speed, laden/unladen
5.2		Lift Speed, laden/unladen	ft/min (m/s) 1.97/2.36 (0.050/0.060)
5.3		Lowering Speed,laden/unladen	ft/min (m/s) 1.57/1.77 (0.040/0.045)
5.8		Max Gradeability, laden/unladen	% 6/15
Electric Motor		6.1	Drive Motor Rating S2 at 60 min
	6.2	Lift Motor Rating S3 at 15%	hp/kW 1.07/0.8
	6.4	Battery Voltage, rated capacity	V/Ah 2x12/70
	8.1	Type of Drive Control	DC
	9.1	Manufacturer	Curtis

Note: 1) VDI 2198: +14.1/358mm 2) VDI 2198: +7.9/200mm 3) When fork lowered,+2.4/60mm

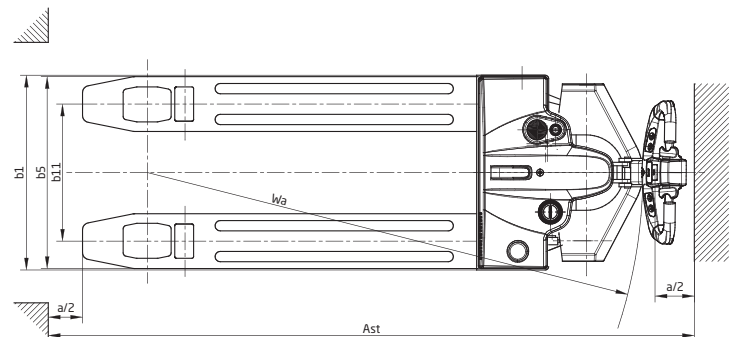
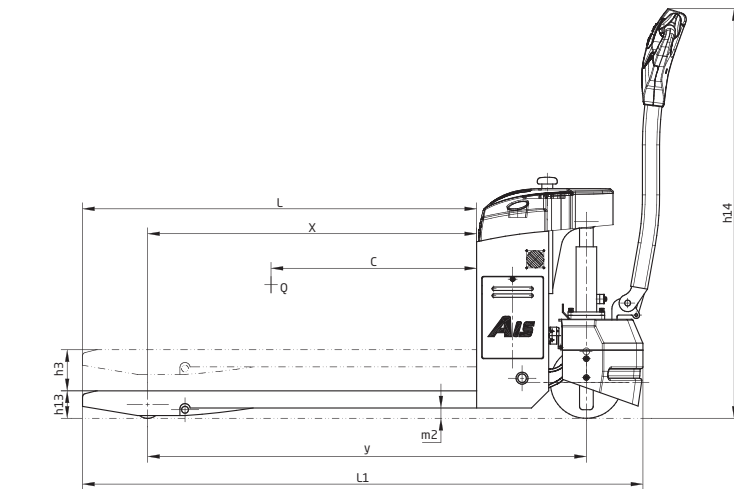

HANGCHA

MONTACARGAS REMMOSA SA DE CV

Site:

Vía Jose Lopez Portillo Km. 29.5,
San Lorenzo Tetlixtac, C.P. 55714, Coacalco,
Edo. Méx.

Phone : 552600 2960

ventas@montacargas-hangcha.com
www.montacargas-hangcha.com



2021 VERSION / COPYRIGHT 2021

HANGCHA GROUP CO., LTD. reserves the right to make any changes without notice concerning colors, equipment, or specifications detailed in this brochure, or to discontinue individual models. The colors of trucks, delivered may differ slightly from those in brochures.



A Series Mini Walkie Pallet Truck

with capacities of 3,000lbs

Making Material Handling Easier
SINCE 1956



A Series Mini Walkie Pallet Truck

The A Series Mini Walkie Pallet Truck has been engineered to be both powerful and flexible to meet the requirements of many demanding applications. Whether it's supermarket work, delivery service, stock replenishment, or heavy manufacturing, the A Series Mini Walkie Pallet Truck has the strength and durability to minimize your total cost of ownership.

Easy Efficient Economical

Appearance

- / The A Series Electric Mini Walkie Pallet Jack has a smooth vivid profile and was designed to be ergonomic. The exterior of this forklift is powder coated in a durable, easy to see, red.
- / This pallet truck uses stamped steel plates and injection molded parts. This creates a robust and durable product that is able to successfully take on the wear and tear of a warehouse environment.



High Performance

- / With a rated capacity of 3000lbs, the pallet jack is designed to meet the needs of the majority of operators.
- / The low heat traction motor provides great acceleration and performance.
- / The latest CURTIS control system allows the truck to run efficiently and provides stable control performance.
- / The regenerative braking system prevents the pallet truck from sliding on a slope.
- / The controllers, hydraulic power packs, switches, plug connectors, and other components are all from industry known suppliers to ensure reliability, performance, and ease of service.

Comfort

- / The ergonomic REMA Tiller is designed to provide a comfortable operating experience and allow all operations to be completed with one hand.
- / Optimized designing structure to offer good visibility and easy entrance of the pallet.
- / The built-in charger and maintenance-free gel battery are included to provide a convenient operating experience.
- / Thanks to the compact, lightweight, and flexible design, the pallet jack is easy to operate. The pallet jack is also designed to operate efficiently in narrow aisles environments like a container thanks to its upright walking function.
- / The standard height of the fork is 3.15"
- / The guiding tips on the ends of the forks make loading and unloading pallets, including closed-deck pallets, easier.
- / Standard, the battery can be removed from the side of the pallet jack. The small and lightweight battery pack can be replaced quickly and easily.

Reliability

- / The three-point support design and side support system provide increased safety and stability to the pallet jack.
- / The electrical system uses waterproof connectors and protection on the wires and cables to improve the electronic's reliability.
- / The low noise and vibration hydraulic power unit enables stable and reliable lifting and lowering.
- / The punched-formed forks provide higher strength and are impact-resistant.
- / The non-contact proximity switch greatly improves the operational safety and reliability of the pallet jack.

Safety

- / The pallet jack includes release braking, reverse braking, and emergency braking to ensure safe driving.
- / Anti-slope on gradient can keep the safety.
- / The pallet jack also features an anti-rollback function to ensure safe operation.
- / The emergency reverse button on the handle can effectively prevent the driver from being injured if the pallet jack moves forward in an emergency situation.
- / The electronic lifting limit and mechanical limit switches prevent an impact caused by lifting goods to the top of the lifting range. This protects both the motor and the goods from being damaged.
- / The pallet jack automatically goes into sleep mode after 30 minutes on standby to increase energy efficiency and safety.



Maintenance

- / The maintenance-free gel battery means that the operator doesn't have to perform routine maintenance on the battery.
- / The maintenance hatch hood opens very easily to expose all components and facilitate easy maintenance of the pallet jack.
- / All rotating shafts are equipped with self-lubricated sleeves and oil cups to promote a long service life.

Standard Specifications

- / Permanent Magnet Drive Motor
- / CURTIS Permanent Magnet Controller
- / Emergency Cut-Off Switch
- / Multi-Function Battery Indicator
- / PU Wheel
- / 45.3" Fork Length
- / 27" Outside Fork Width
- / Electronic Lifting Limit Feature
- / Non-Contact Proximity Switch
- / REMA Tiller Head
- / Horn
- / Maintenance-Free Battery
- / Internal Charger
- / Walking Upright Feature
- / Guiding Tips
- / Caster Wheel
- / Single Load Wheel

Options

- / Various Fork Lengths
- / Various Fork Widths
- / Tandem Load Wheel



REMA Tiller Head



Auxiliary wheels are equipped to give the pallet truck better stability.



The key switch, emergency cut-off switch, and battery meter are all easily accessible by the operator.



The guiding tips on the ends of the forks make loading and unloading pallets easier.